



Wind Turbine Optimization with WISDEM

Katherine Dykes, Rick Damiani, Andrew Ning (BYU),
Peter Graf, George Scott, Ryan King, Yi Guo,
Julian Quick, Latha Sethuraman, and Paul Veers

Fourth Wind Energy Systems Engineering Workshop

Sept. 13–14, 2017

Danish Technical University, Roskilde, Denmark

Motivation and Needs

- Wind plants are technically complex and highly coupled systems
- Plant design, development, and operations are partitioned across a large industry between sub-sectors
- This results in sub-optimal system-level performance and cost and risk aversion to the adoption of new innovations.

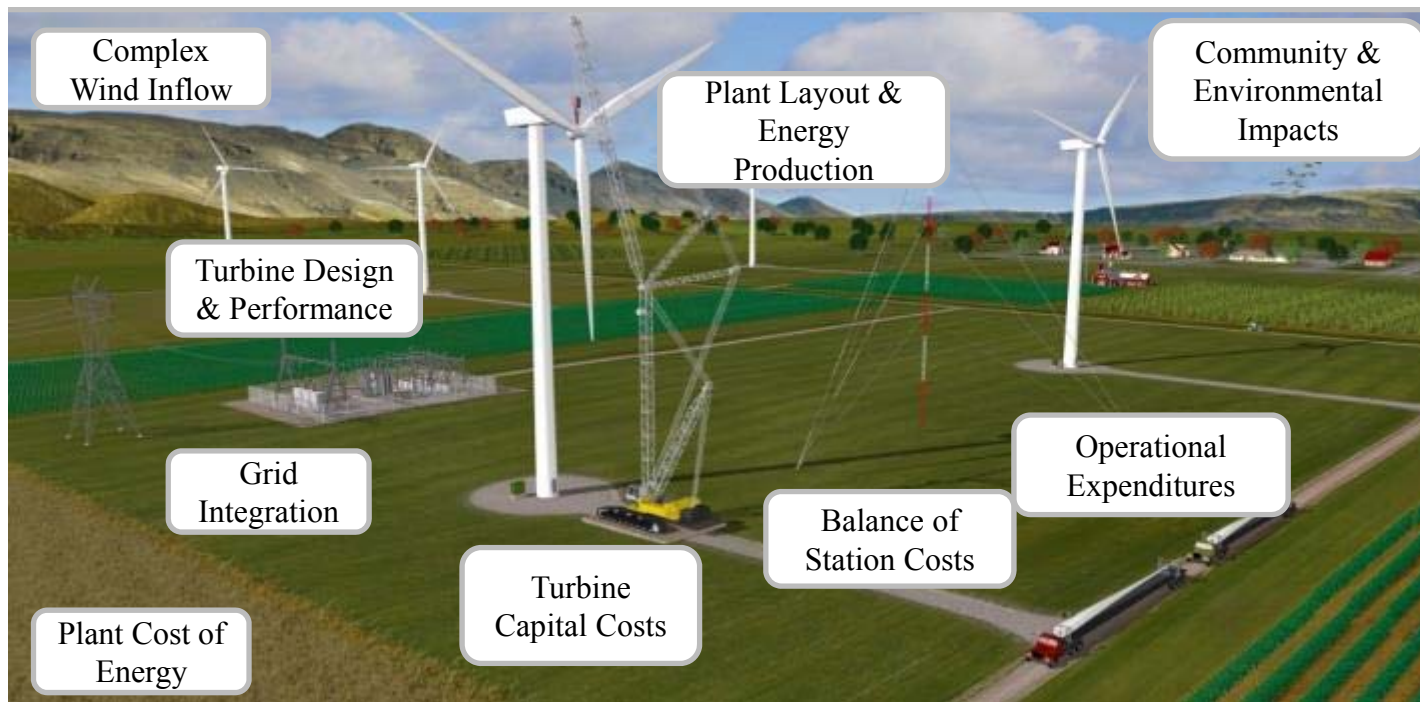

*A full wind plant involves stakeholders and large technical complexity.
Graphic: Al Hicks, NREL*

Wind Energy Systems Engineering

To address these challenges, the NREL wind energy systems engineering initiative has developed an analysis platform and research capability to capture important system interactions to achieve a better understanding of how to improve *system-level* performance and achieve *system-level* cost reductions.

Objectives include:

- Integrating wind plant engineering performance and cost software modeling to enable full system analysis
- Applying a variety of advanced analysis methods in multidisciplinary design analysis and optimization (MDAO) and related fields to the study of wind plant system performance and cost
- Developing a common platform and toolset to promote collaborative research and analysis among national laboratories, industry, and academia.

Wind-Plant Integrated System Design & Engineering Model

The Wind-Plant Integrated System Design & Engineering Model (WISDEM)TM creates a virtual, vertically integrated wind plant from components to operations.

Framework for Unified Systems Engineering and Design of Wind Plants (FUSED-Wind)

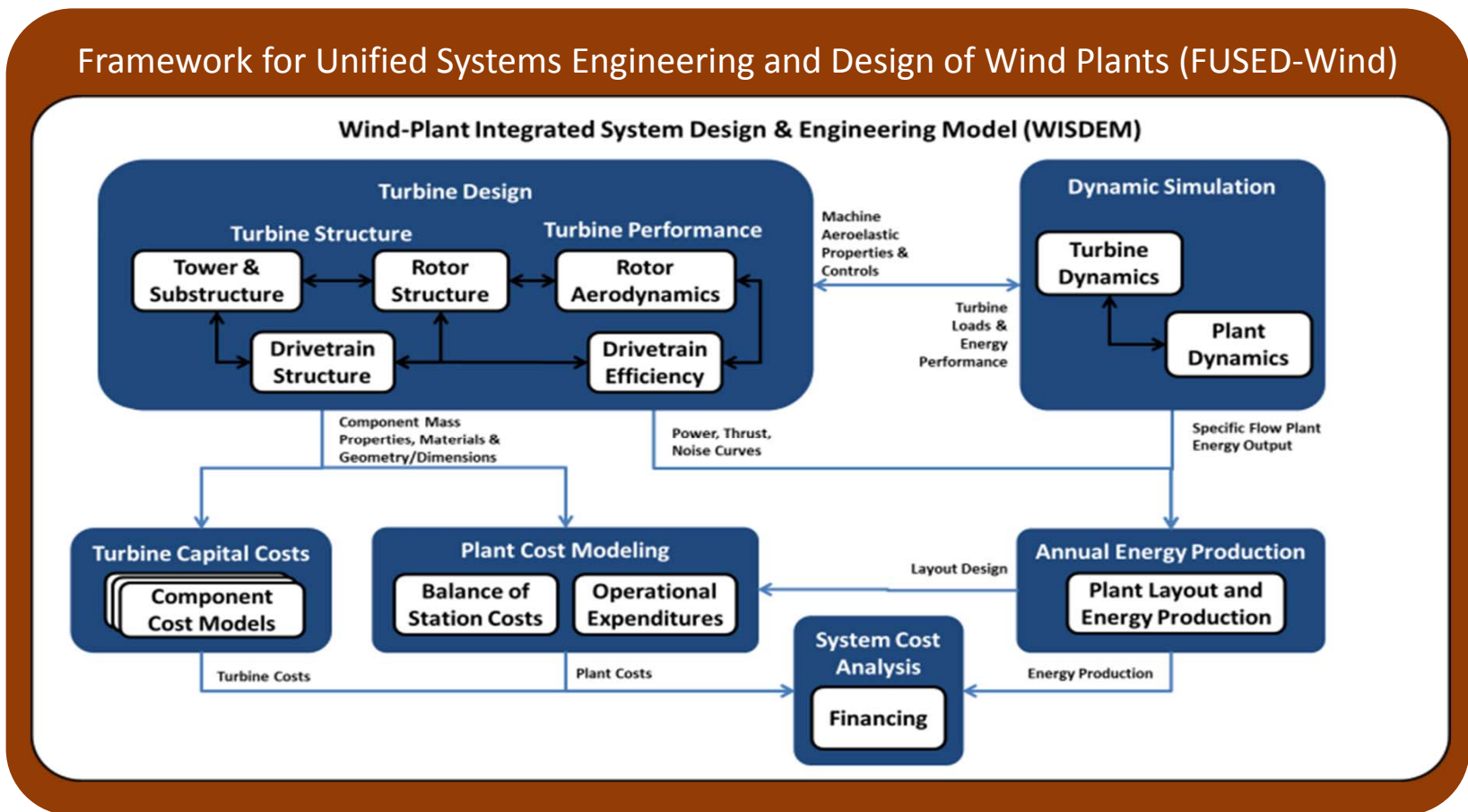

<http://nwtc.nrel.gov/WISDEM>

MDAO Research for Wind Energy

- Using FUSED-Wind/WISDEM, we demonstrate value of integrated system modeling and MDAO
 - Integrated turbine design (rotor aero-structure, full turbine optimization)
 - Integrated plant design and operations (wind plant controls and layout, layout and hub height, layout and support structure)
 - Integrated turbine and plant optimization (multi-turbine layout designs, site-specific turbine/support structure design)

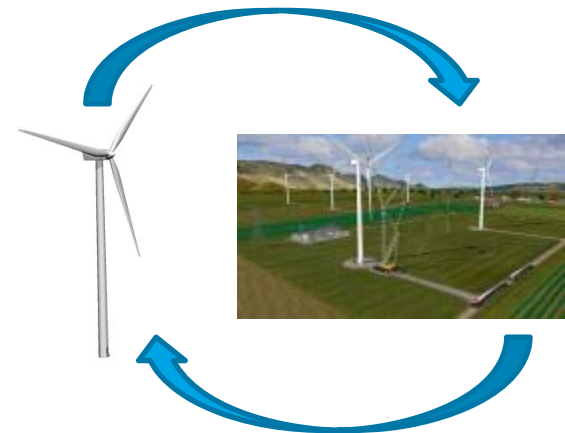

MDAO Research for Wind Energy

- Using FUSED-Wind/WISDEM, we investigate novel approaches to wind system analysis and MDAO

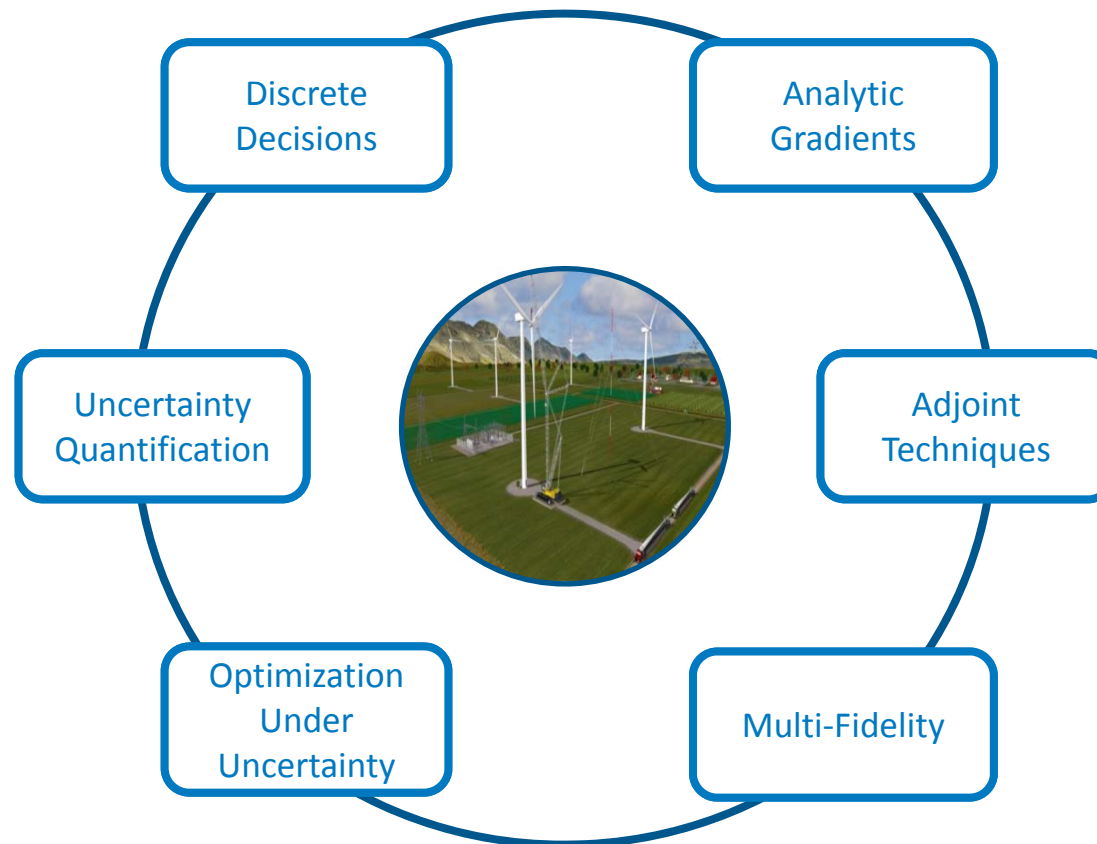

Today's focus is wind turbine optimization from a cost-of-energy (COE) perspective:

Used in this analysis

Framework for Unified Systems Engineering and Design of Wind Plants (FUSED-Wind)

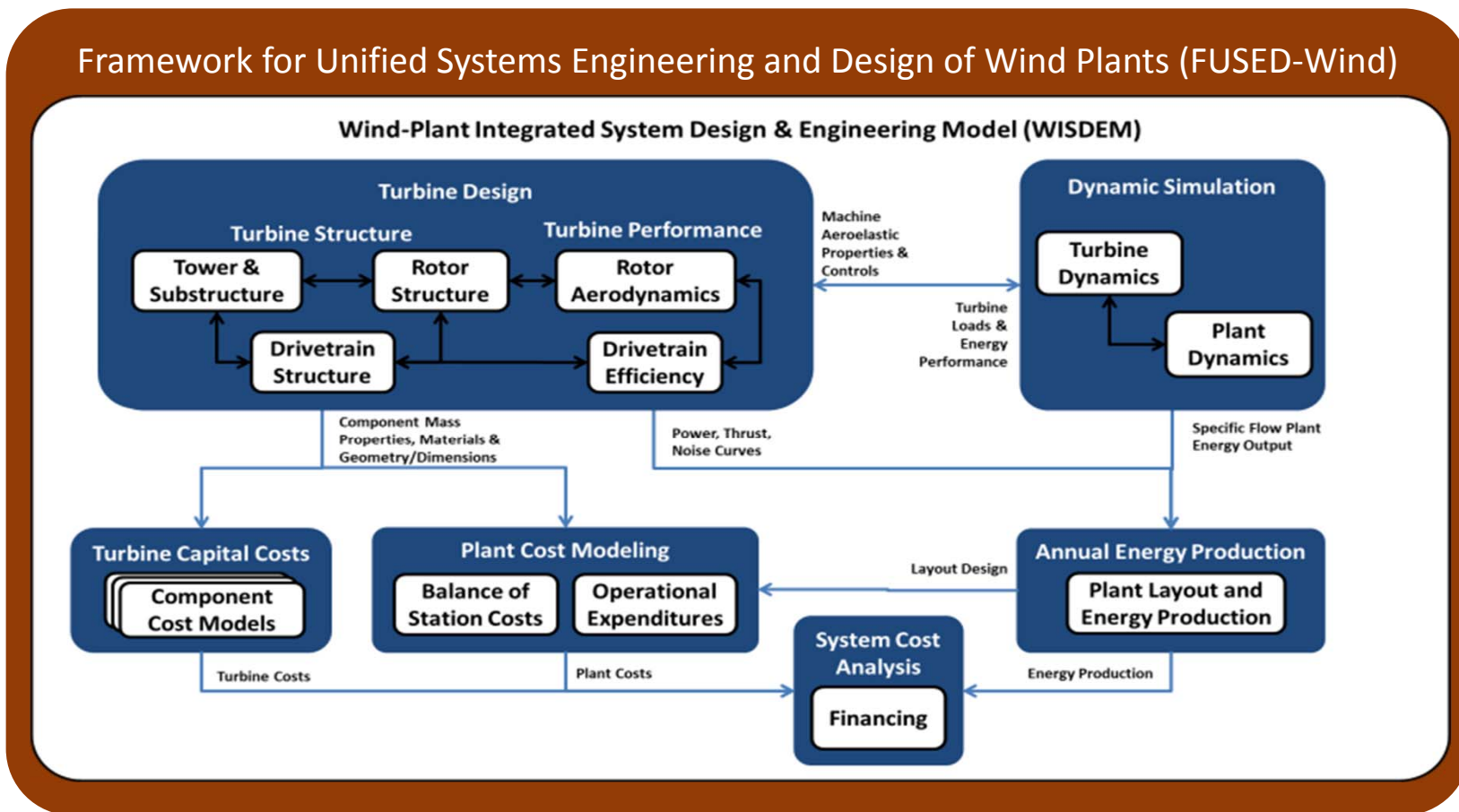

<http://nwtc.nrel.gov/WISDEM>

Analytic
Gradients

Integrated
Turbine Design

WISDEM: Examples and Applications

Turbine Design—Downwind versus Upwind



WISDEM : TurbineSE—Downwind vs. Upwind

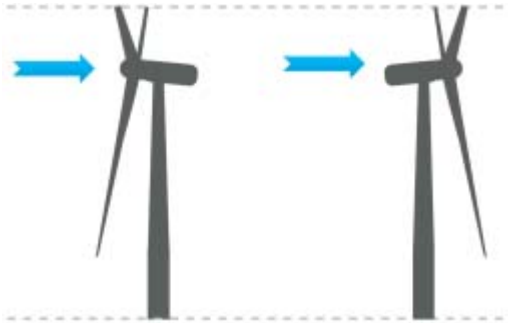

The Background:

Potential Advantages of Downwind Turbines:

1. Slenderer and softer blades (reduce tower strike constraint)
2. Increased efficiency with inclined flow

→ Reduced levelized cost of energy (LCOE)?

The Method:

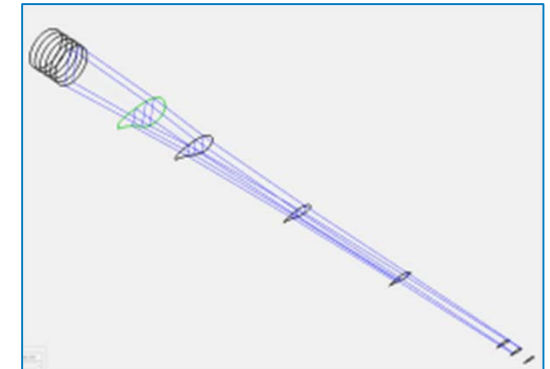

Analytic gradients

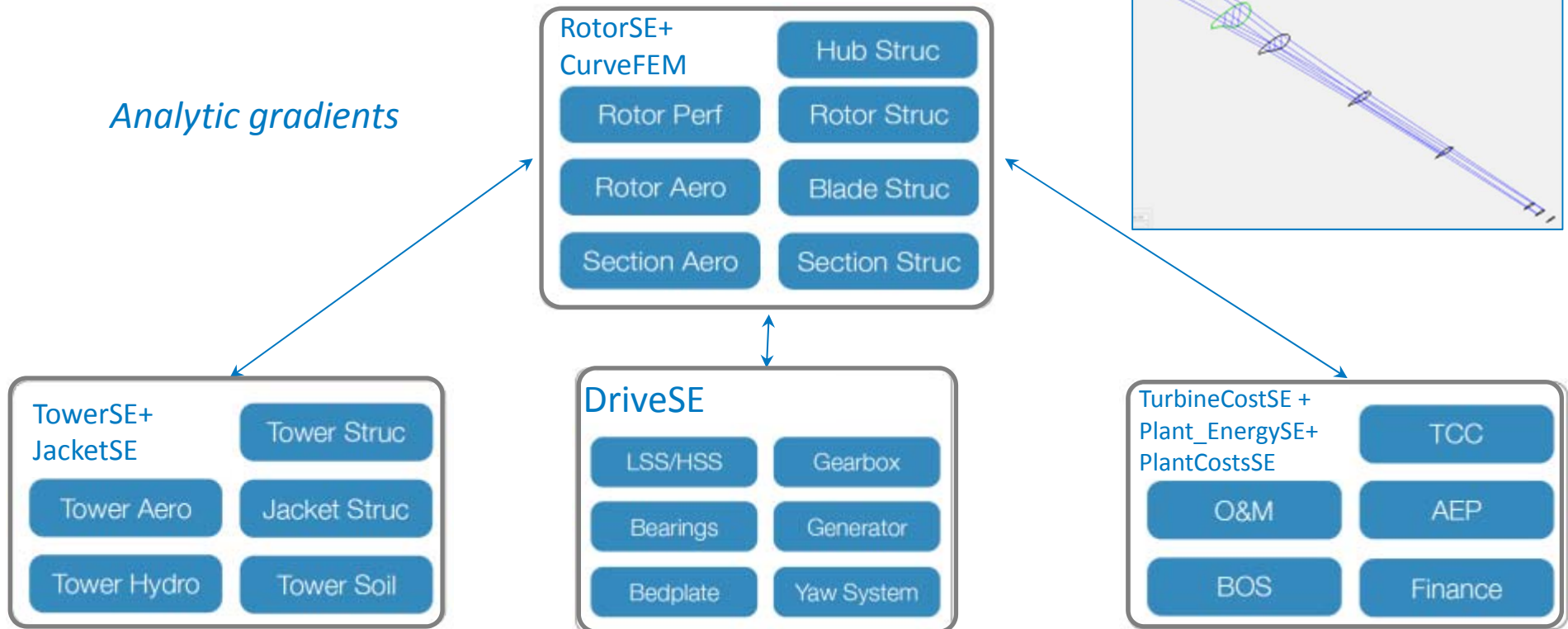

WISDEM : TurbineSE—Downwind vs. Upwind

- 35 design variables
- Chord + twist distribution
- Spar-cap + aft panel thickness distribution
- Pre-curve distribution
- Tip-speed ratio
- Bedplate I-beam dimensions
- Low speed shaft length
- Tower outer diameter + wall thickness
- Tower height
- Tower waist location
- 100+ constraints
- Natural frequency
- Deflections (tower clearance)
- Ultimate limit state strains/stresses
- Fatigue limit state damage
- Max Tip speed (80 meters/second)
- Transportation (chord ≤ 5.3 meters)
- TowerSE + DriveSE...
 - Buckling/strength requirements
 - Manufacturability and Weldability
 - And more!

- IEC Design Load Cases (DLCs) 1.3, 6.2
- Constant laminate schedule (variable thickness)

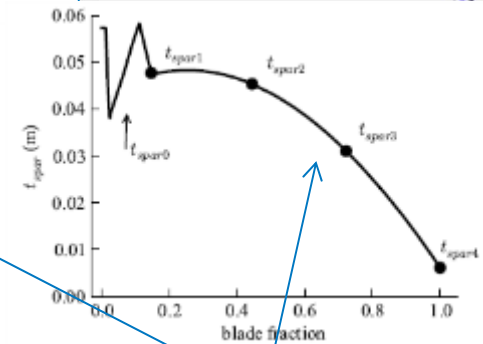
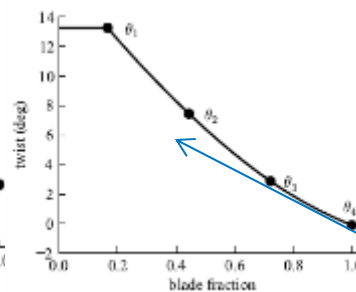
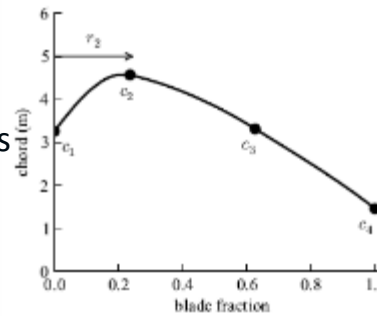
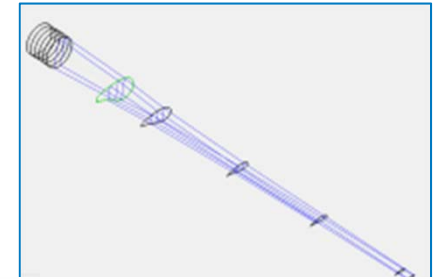

$$f_0 \geq 1.1 n_{blades} \Omega_{rated}$$

$$\delta_{tip} \eta_{dfl} \leq \delta_{max}$$

$$-\epsilon_{ult} \leq \epsilon \eta_{str} \leq \epsilon_{ult}$$

$$\epsilon \leq \epsilon_b \quad \epsilon_b = -\frac{N_{cr}}{T E}$$

Akima Spline

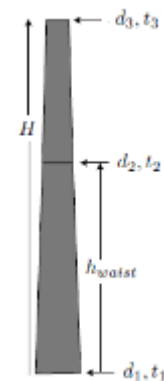

Objective function: COE ~ mass / AEP

WISDEM : RotorSE—Downwind vs. Upwind

SNOPT (optimizer) + analytic gradients

- Nonlinear optimization problems using sequential programming
- Optimizations were formulated in the OpenMDAO framework

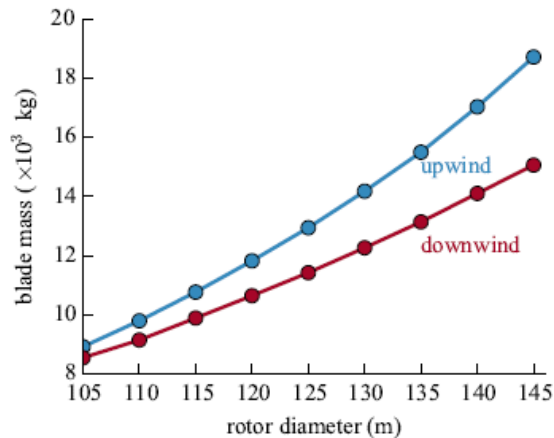

Blade Mass reduced but...



Tower Mass increased



Annual Energy Production (AEP) basically unchanged

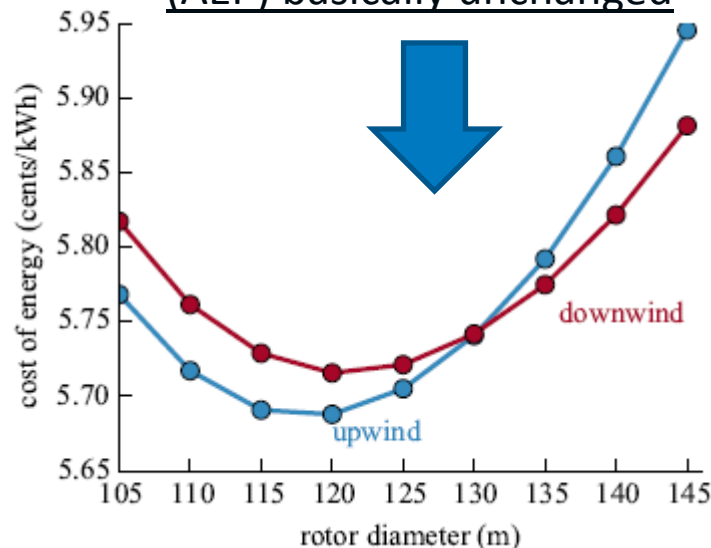

NREL Class I 5 MW Reference Turbine

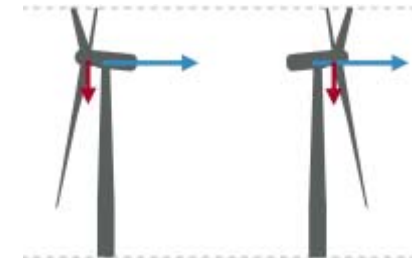
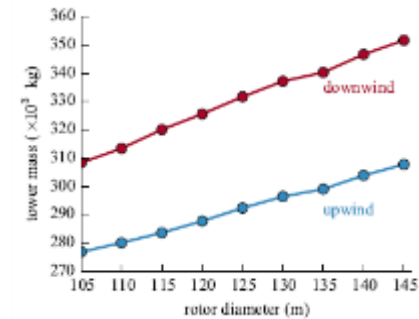

- Minimal LCOE reduction at larger rotor diameters, but minimum LCOE with upwind machines
- Survival DLC dominant

WISDEM : TurbineSE—Downwind vs. Upwind

SNOPT (optimizer) + analytic gradients

- nonlinear optimization problems using the sequential programming method, and
- the optimizations were formulated in the OpenMDAO framework

Class III 5 MW

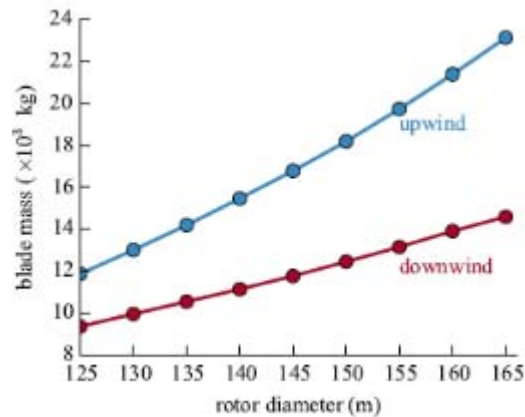

Blade Mass reduced (30%) but...



Tower Mass increased



1% lower AEP

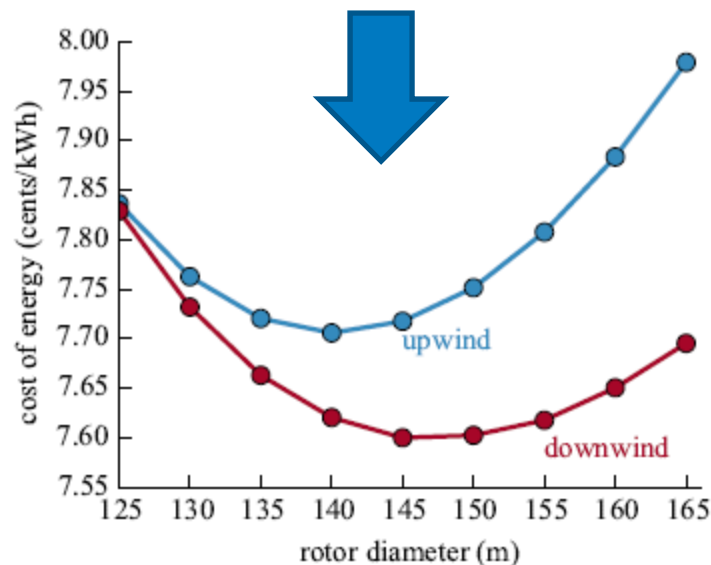
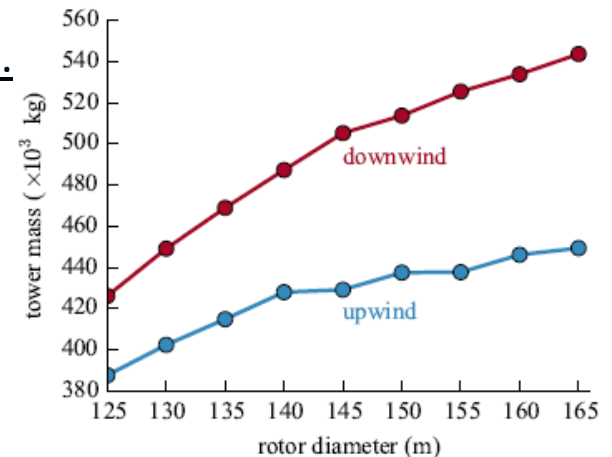

1.5% LCOE reduction at larger rotor diameters and minimum LCOE with downwind rotors

Analytic
Gradients

Integrated
Turbine Design

WISDEM: Examples and Applications

Impact of Higher Tip Speed on Turbine Design



Tip Speed Investigations

- Increasing tip speed benefits expected largely in reduction of drivetrain
- Two studies performed:
 - Sequential optimization of the wind turbine followed by plant-level COE analysis
 - Higher fidelity rotor optimization
 - Integrated system level optimization with overall COE objective.

Study 1: Sequential Optimization

- Collaborative effort with Sandia National Laboratories (SNL)
 - High fidelity rotor modeling by SNL for rotor followed by WISDEM-based drivetrain, tower design, and system cost analysis by NREL.
- COE reduction of $\sim 1.5\%$ mainly due to reduction in gearbox size
- Significant trade-offs in blade dimensioning and weight compared to energy production and drivetrain dimensioning.



Baseline gearbox at 80 m/s tip speed



Reduced size gearbox at 100 m/s tip speed

Study 2: Integrated System Optimization

- Rotor, drivetrain, and tower designed in simultaneous process using COE as overall system objective
 - Uses full set of models for WISDEM version 1.0.
- Analysis uses lower fidelity tool but explores design space over a range of tip speeds, turbine class, and site conditions, and variations in rotor diameter and hub height
- Cost reductions of ~5% seen for a variety of turbine/site configurations.

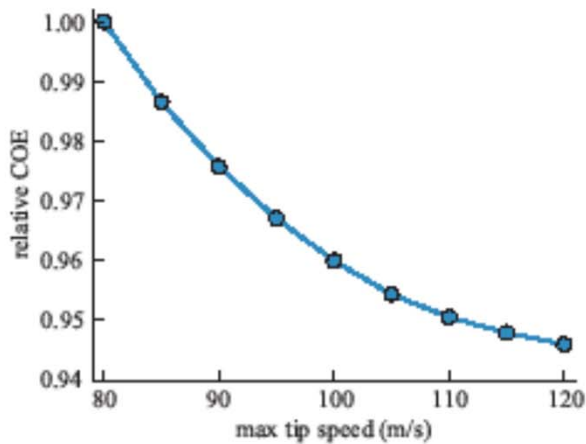

a) Class IB turbine

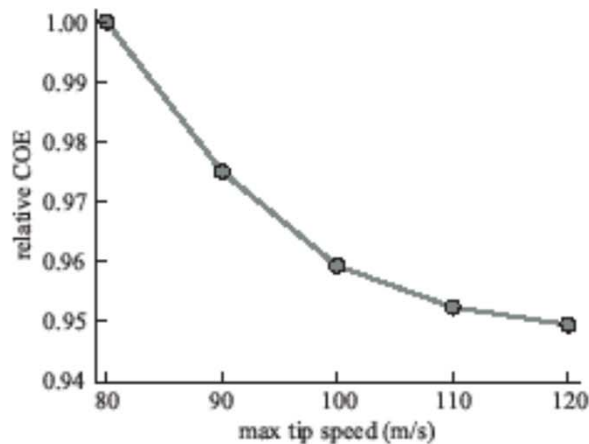

b) Class IIIB turbine

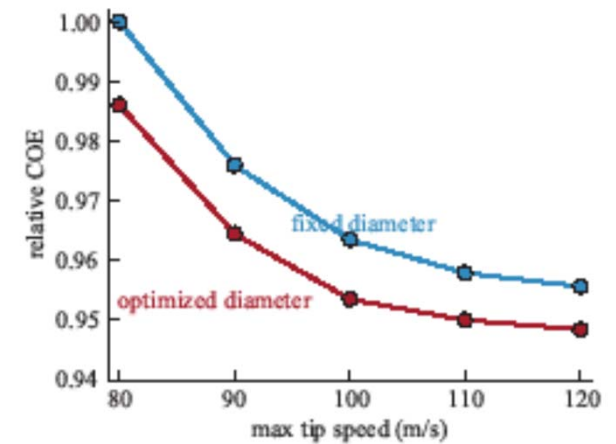

c) Class 1B variable rotor size

5% cost of energy reduction possible moving to very high tip speeds of 120 m/s

Analytic
Gradients

Integrated
Turbine Design

WISDEM: Examples and Applications

Turbine Design with Segmented Blades



Sensitivity Analysis

- Sensitivity analysis for segmentation to be run around main innovation impact variables
 - In this case using Monte Carlo analysis with DAKOTA via WISDEM.

Downside Impact	Upside Impact
Blade weight/Turbine weight	Transportation
Blade manufacturing cost	Blade manufacturing cost
Field assembly labor, tooling & facilities/staging	Turbine assembly/erection costs
Operational expenditures	Operational expenditures

Current Technology with Segments

- Interior U.S. Region Results
- Segmented Case Sensitivity Ranges:

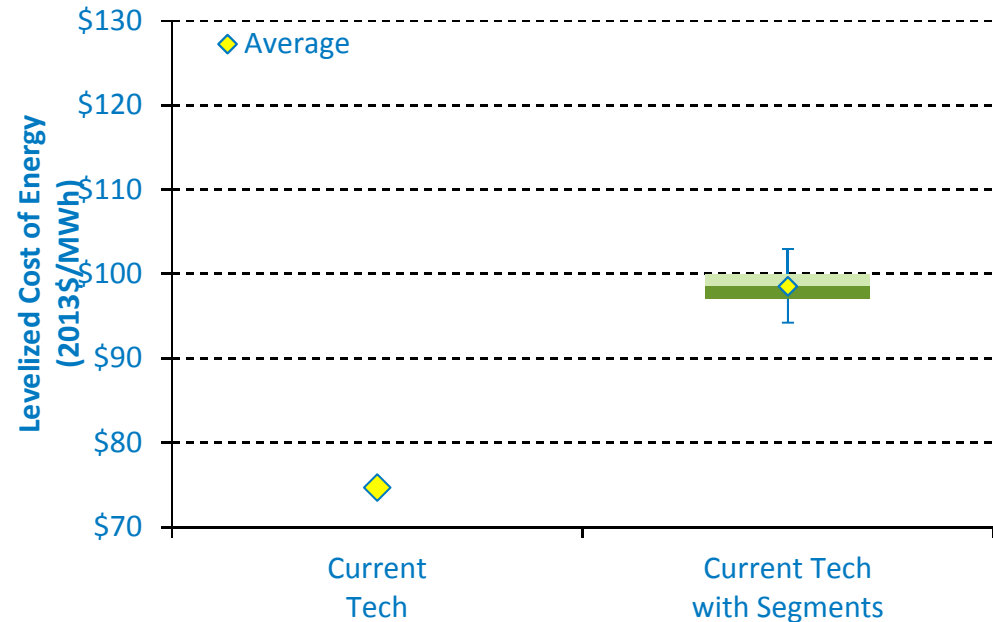

- **Current technology has relatively low COE (using 2013 U.S. Dollars [USD])**
- **Segmented blades are unlikely to capture market share if they are competing with current technology in existing markets.**

	Low %	High %
Blade Mass	100%	130%
Blade Cost	80%	120%
BOS Buildings	100%	200%
OPEX	90%	110%

Current and Future Technology with Segments

- Results for Interior and Southeastern U.S. regions
- Non-Segmented Case Sensitivity ranges:

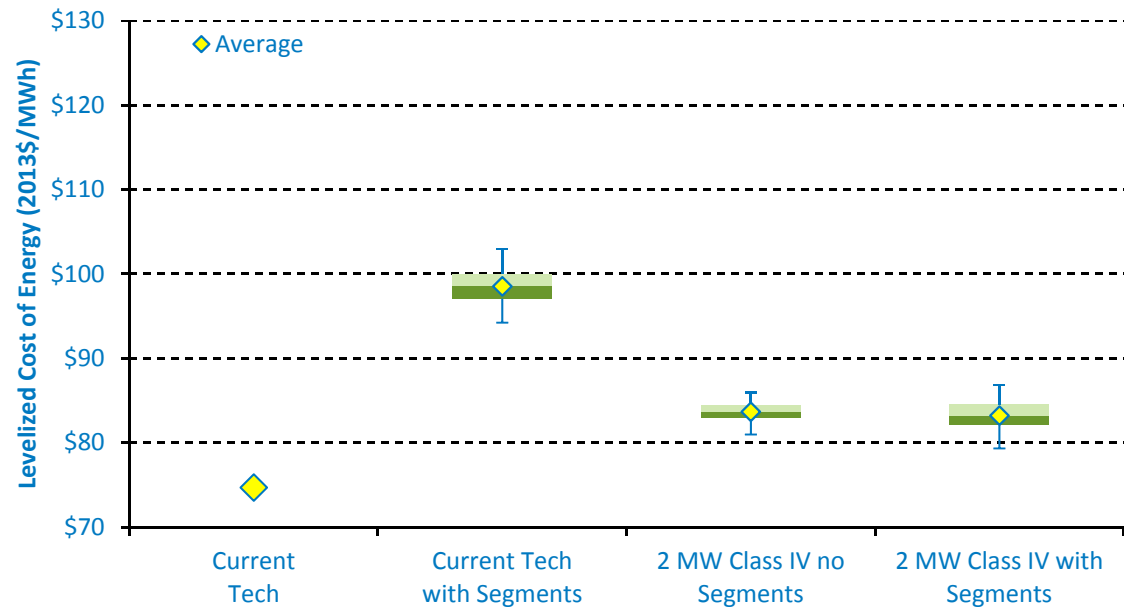

- **Current technology still has an estimated advantage over low-wind speed technology segmented or unsegmented future technology for interior region sites.**

	Low %	High %
Blade Transport	100%	300%
Turbine Assembly	100%	300%

All Technology Scenarios

- Interior region analysis (mid- to high-wind resource sites)

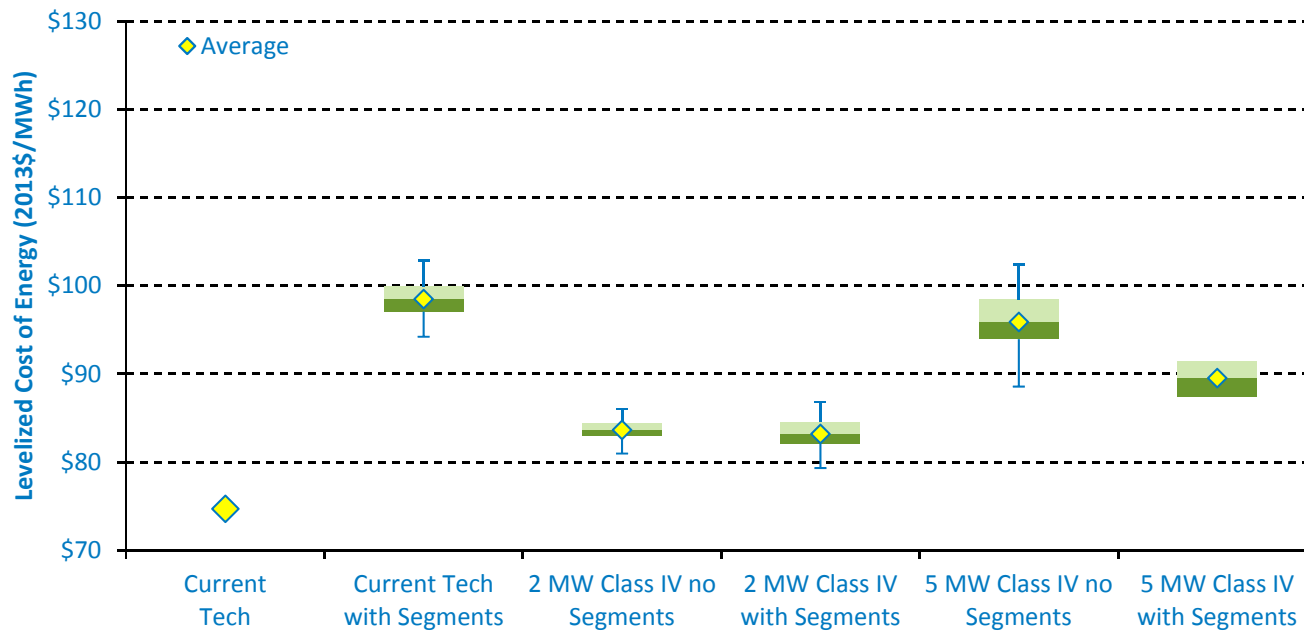

- Current technology is the overall winner if we are considering sites that are already suitable for development today.**

All Technology Scenarios

- Southeast Region Results (low-wind resource sites)

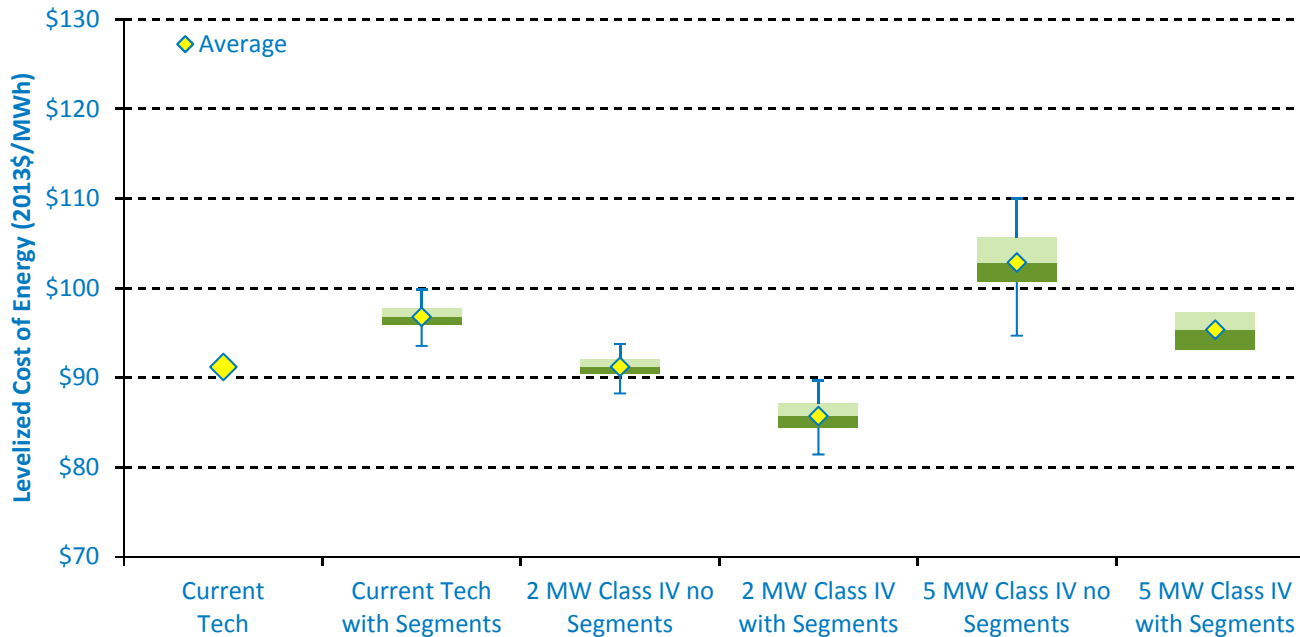

- **However, when we look at markets that cannot be developed with current technology, such as the southeast, then segmented blade technology holds promise to provide a more cost effective solution**
- **Results depend on sensitivity range estimates and also model uncertainty, which is not quantified at present.**

Summary

- Integrated MDAO of full wind turbines (or even wind plants) can expose non-intuitive dependencies in system design
- Case studies in higher tip speed, downwind and segmented blade designs illustrate the importance of full system analysis when evaluating technology innovation
- Future work will explore new innovation concepts as well as leverage improved modeling capability across turbine and plant models (especially improving cost model coupling to rest of system models).

Photo by Dennis Schroeder, NREL

Thank you!

www.NREL.gov/wind/systems-engineering.html

We acknowledge the support by the U.S. Department of Energy under Contract No. DE-AC36-08GO28308 with the National Renewable Energy Laboratory. Funding for the work was provided by the DOE Office of Energy Efficiency and Renewable Energy, Wind and Water Power Technologies Office.

References

<http://www.nrel.gov/wind/systems-engineering-publications.html>

- Ning, A.; Petch, D. (2014) Integrated Design of Downwind Land-based Wind Turbines using Analytic Gradients. *Wind Energy*
- Dykes, K.; Resor, B.; Platt, A.; Guo, Y.; Ning, A.; King, R.; Parsons, T.; Petch, D.; Veers, P. (2014). Effect of Tip-Speed Constraints on the Optimized Design of a Wind Turbine. 77 pp.; NREL Report No. TP-5000-61726.
- Ning, A.; Dykes, K. (2014). Understanding the Benefits and Limitations of Increasing Maximum Rotor Tip Speed for Utility-Scale Wind Turbines. Article No. 012087. *Journal of Physics: Conference Series*. Vol. 524(1), 2014; 10 pp.; NREL Report No. JA-5000-61729. <http://dx.doi.org/10.1088/1742-6596/524/1/012087>